

CODES



NAVJO CODE TALKERS
CONGRESSIONAL MEDAL OF HONOR
RECIPIENTS:
DAN AKEE PAUL BLATCHFORD
JOHNNY ALFRED PETER MACDONALD
MIKE KIYAANI MERRILL SANDOVAL

A travers l'histoire du code

Bref aperçu de l'évolution du code, des pythagoriciens qui ont commencé à le mettre en oeuvre, jusqu'à nos jours.

Le code est vu comme un outil, utilisé à la fois et pêle-mêle

- pour comprendre et classer nos connaissances,
- comme référence du beau, du vrai ou du bien
- comme support de communication
- comme masque de la communication
- comme guide d'action
- comme moyen d'action progressivement indépendant

Puisqu'il n'existe pas de langage du code ou de code du code permettant de prendre du recul, cette exploration se fait à pied, en parcourant les personnages et les événements qui ont porté l'évolution du code.

Pythagore -600

Droite et cercle
Des enfers à la Voie Lactée

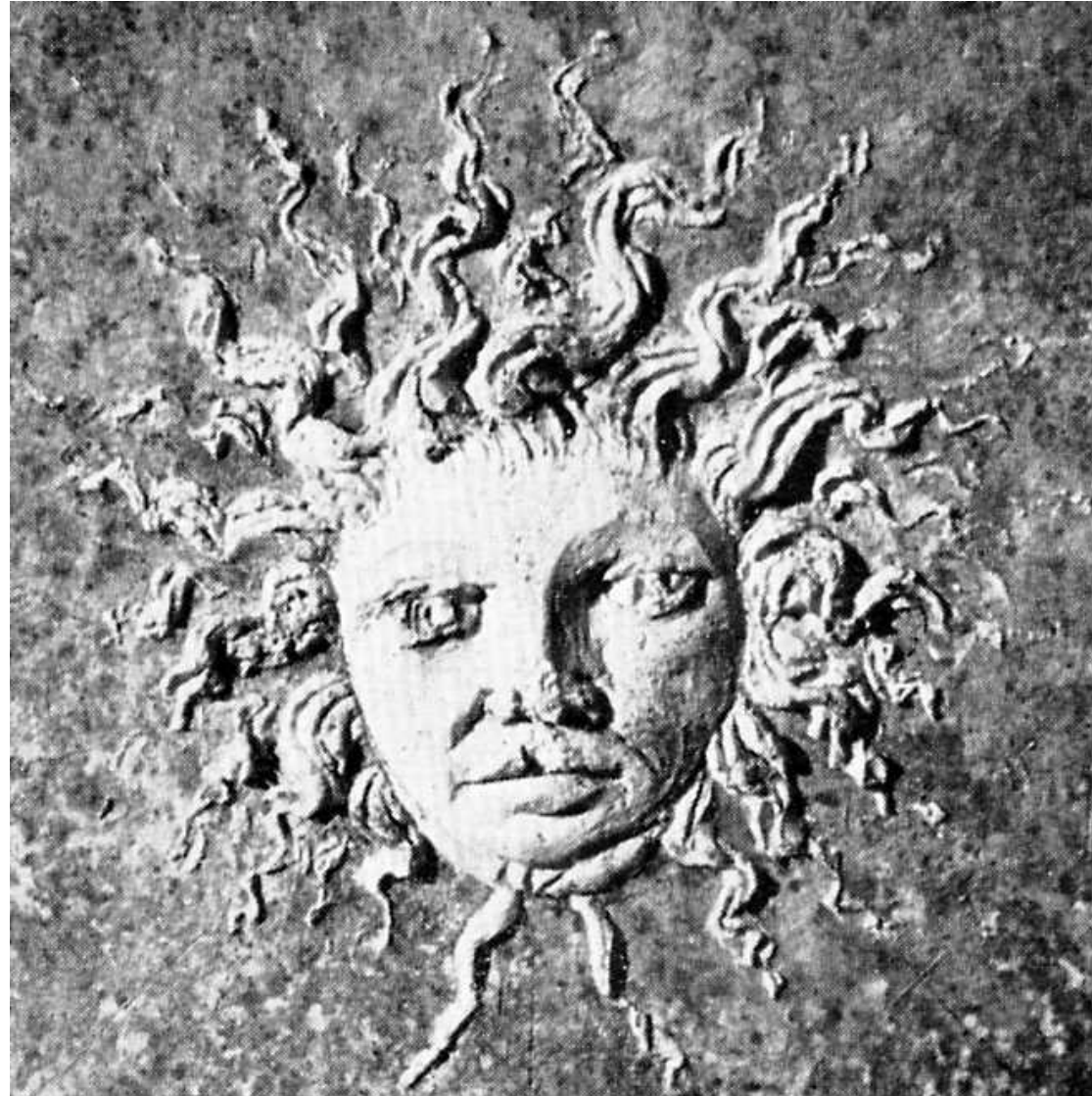

1.61803399...

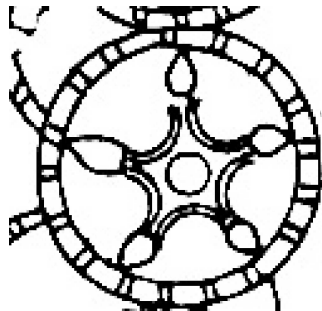
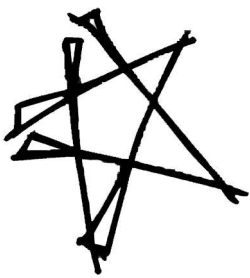
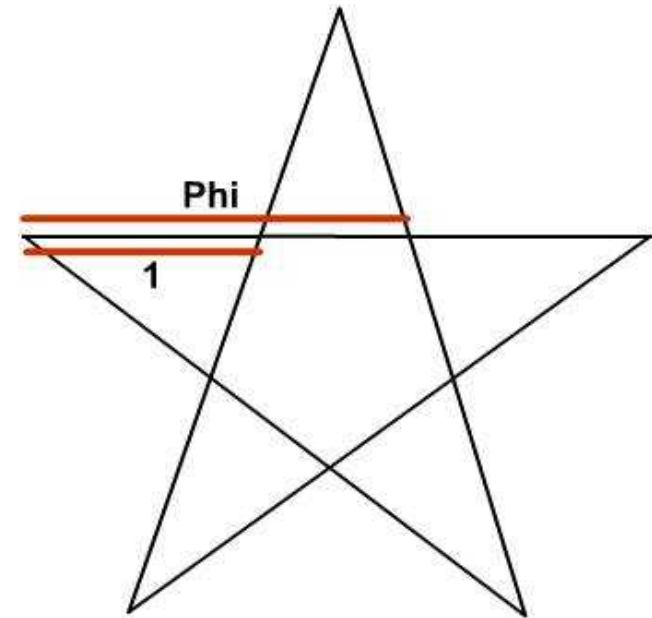
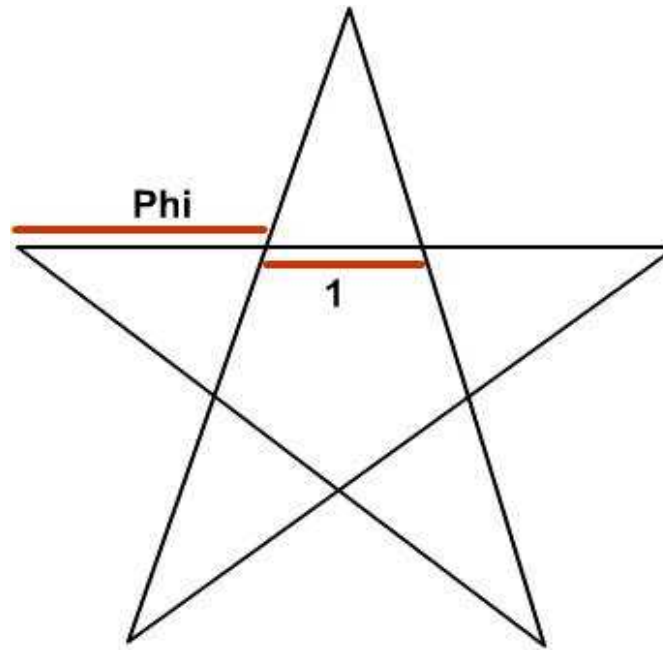

Pythagore, départ du voyage du pentagramme/pentagone

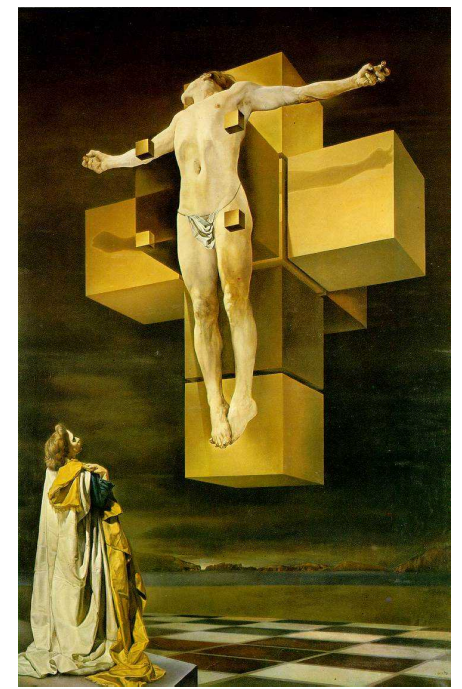
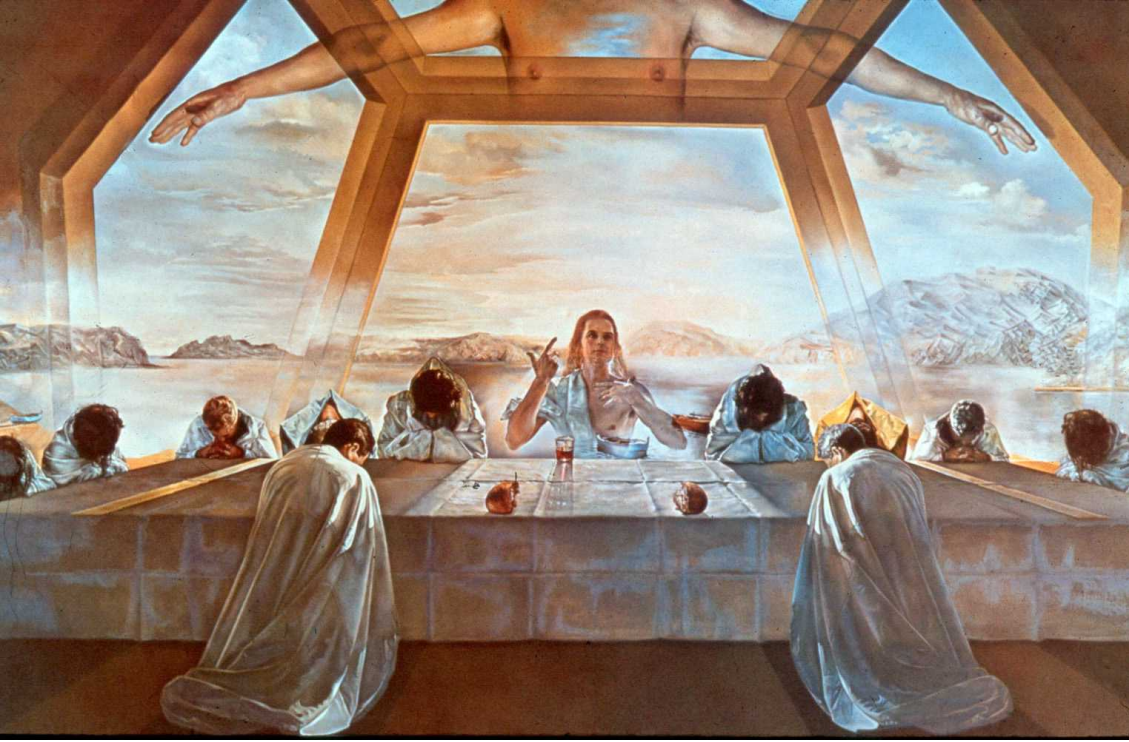

Basilique 1er siècle

Porte Majeure à Rome

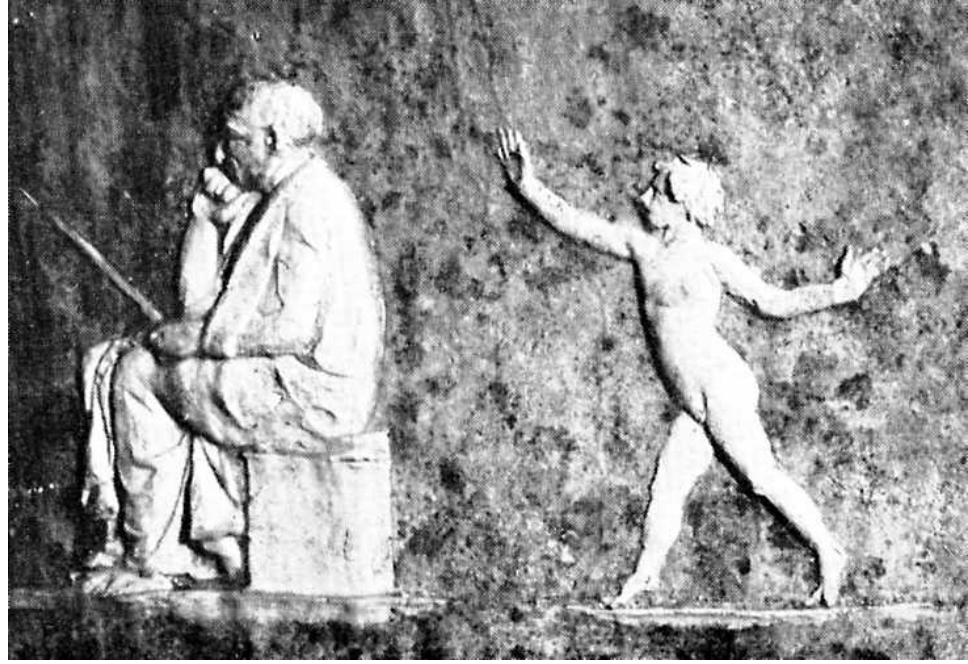
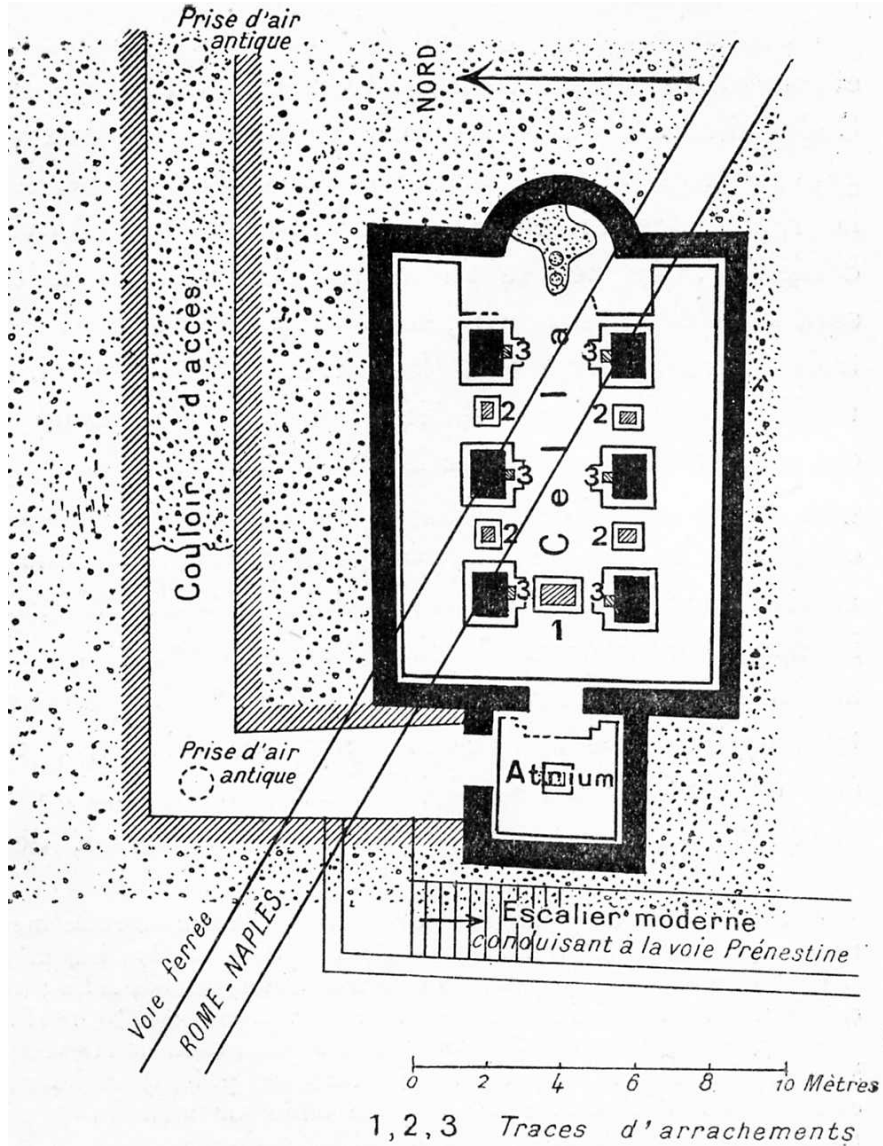

La tour trajane

113

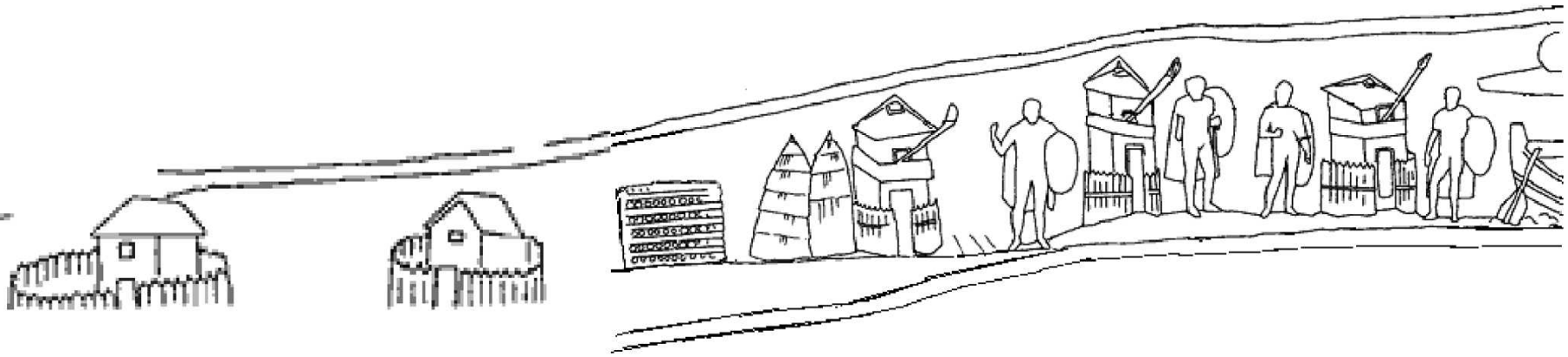
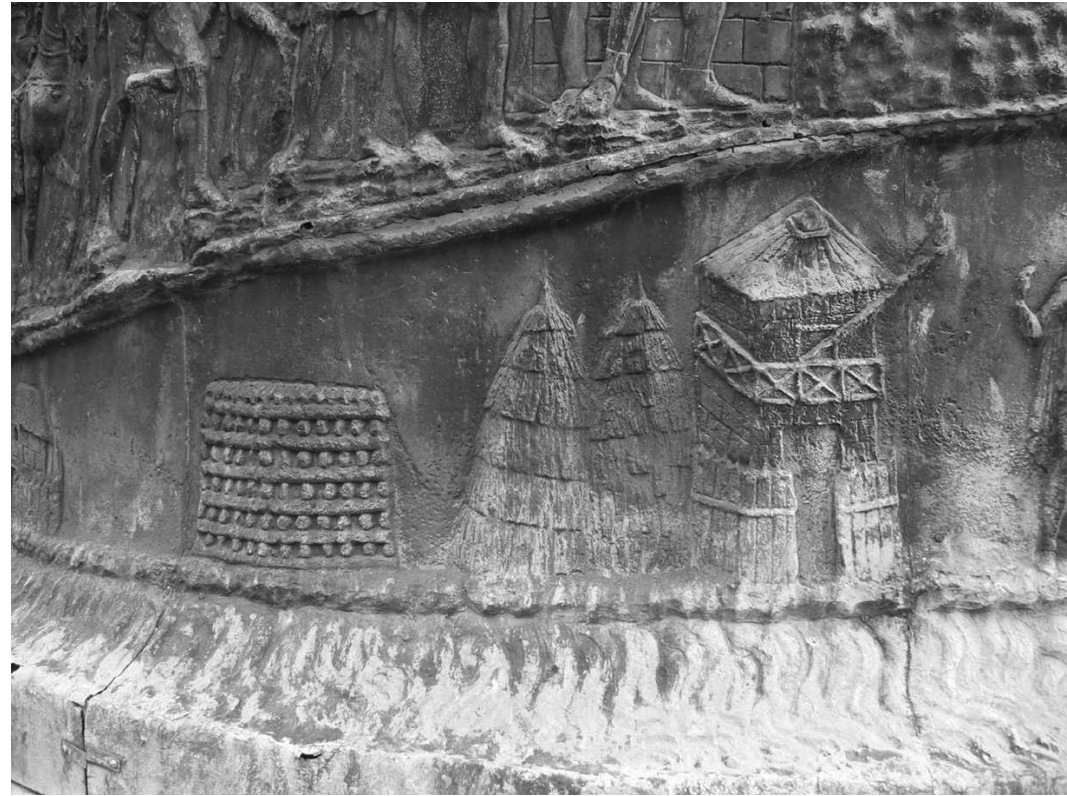

Fibonacci



Léonard de Pise 1170-1250

1 1 2 3 5 8 13

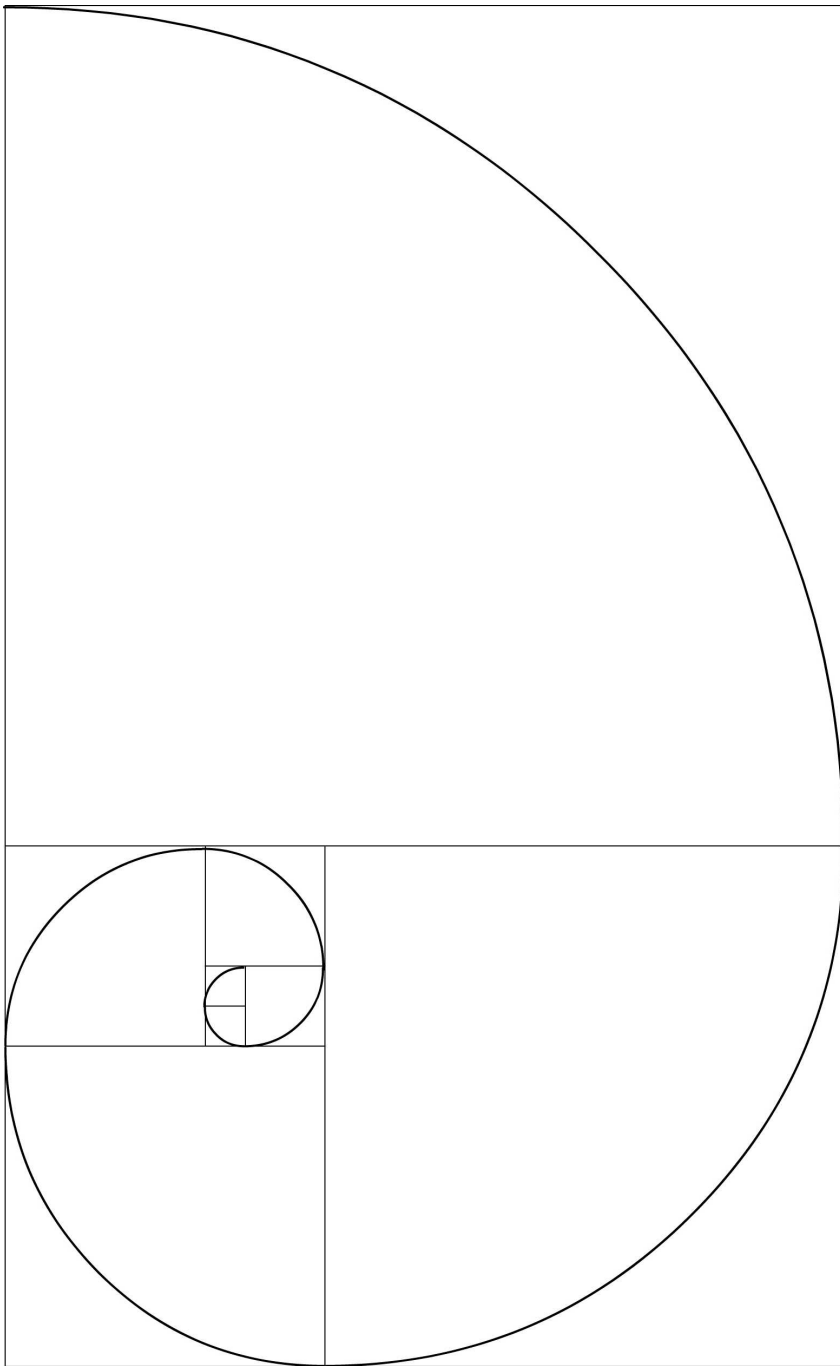

$$\frac{1}{1} \quad \frac{2}{1} \quad \frac{3}{2} \quad \frac{5}{3} \quad \frac{8}{5} \quad \frac{13}{8} \quad \frac{21}{13} \quad \frac{34}{21} \quad \dots$$

1,619

$$\alpha = \sqrt{1 + \sqrt{1 + \sqrt{1 + \sqrt{1 + \dots}}}}$$

$$\alpha = 1 + \frac{1}{1 + \frac{1}{1 + \frac{1}{1 + \dots}}}$$

$$F_n = \frac{(1 + \sqrt{5})^n - (1 - \sqrt{5})^n}{2^n \sqrt{5}}$$

$$\frac{-1 + \sqrt{5}}{2} = 1,618$$

A	B	C
D	E	F
G	H	IJ

L	M	N
O	P	R
S	T	UV

Code des
Templiers ?

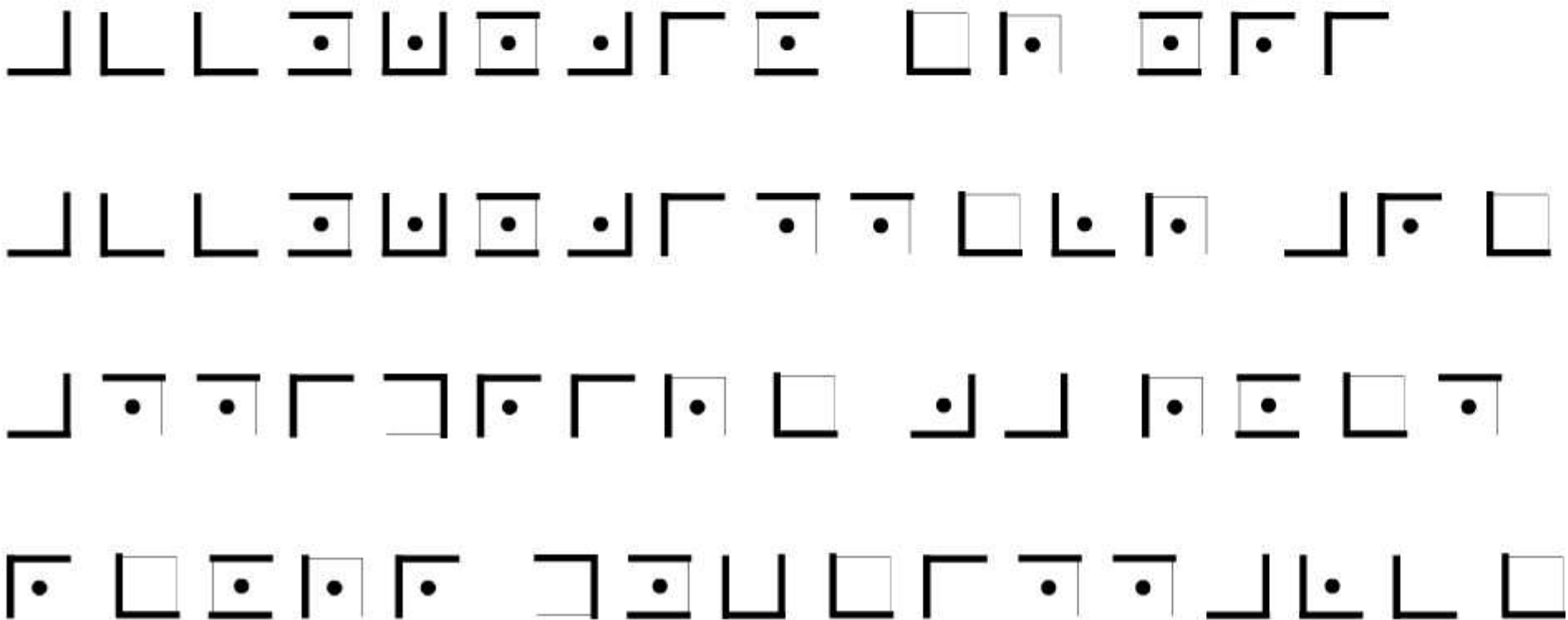

Vinci, XVème

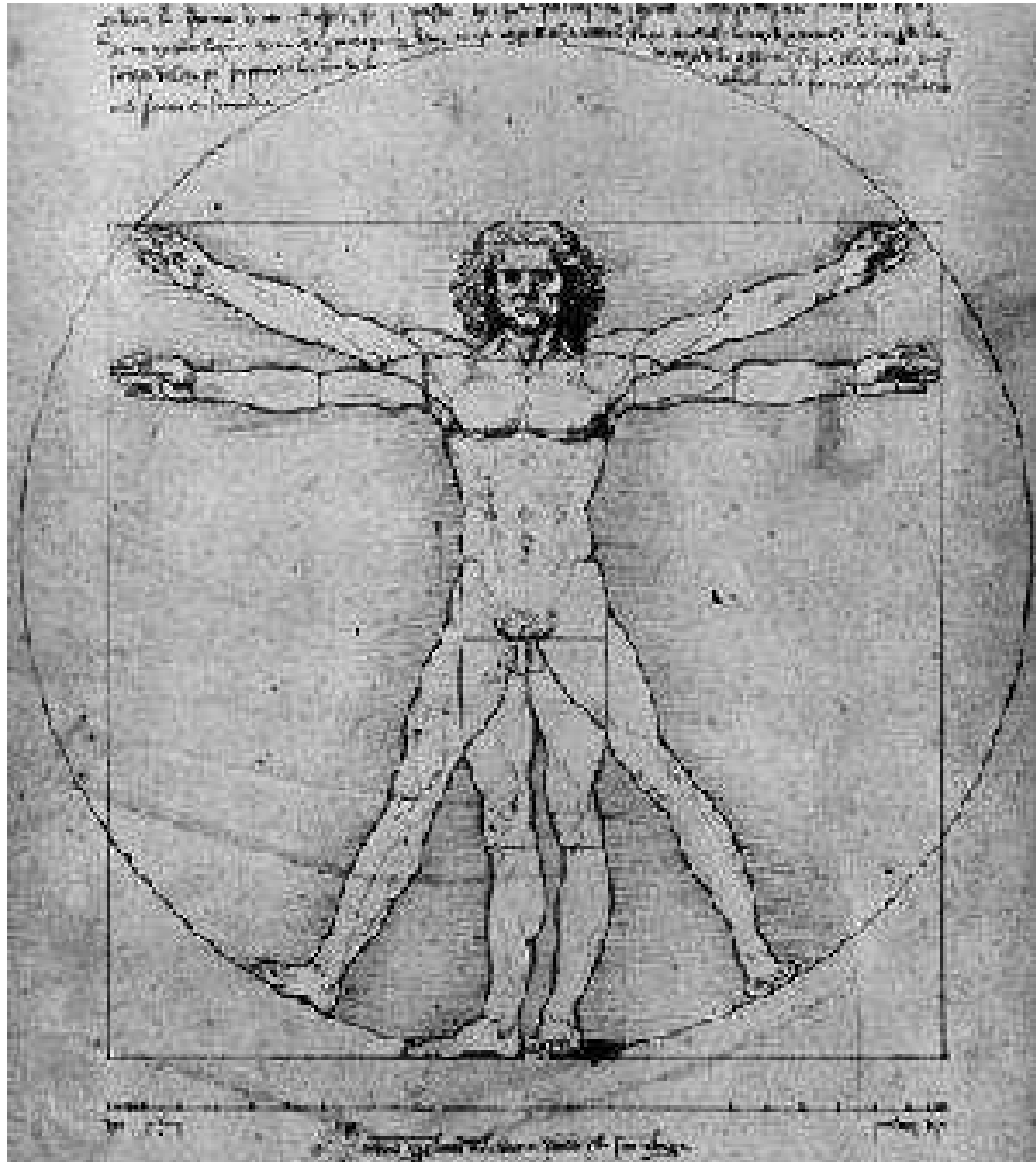

Bracciolini,
1414,
Constance,
St Gall
et
Vitruve

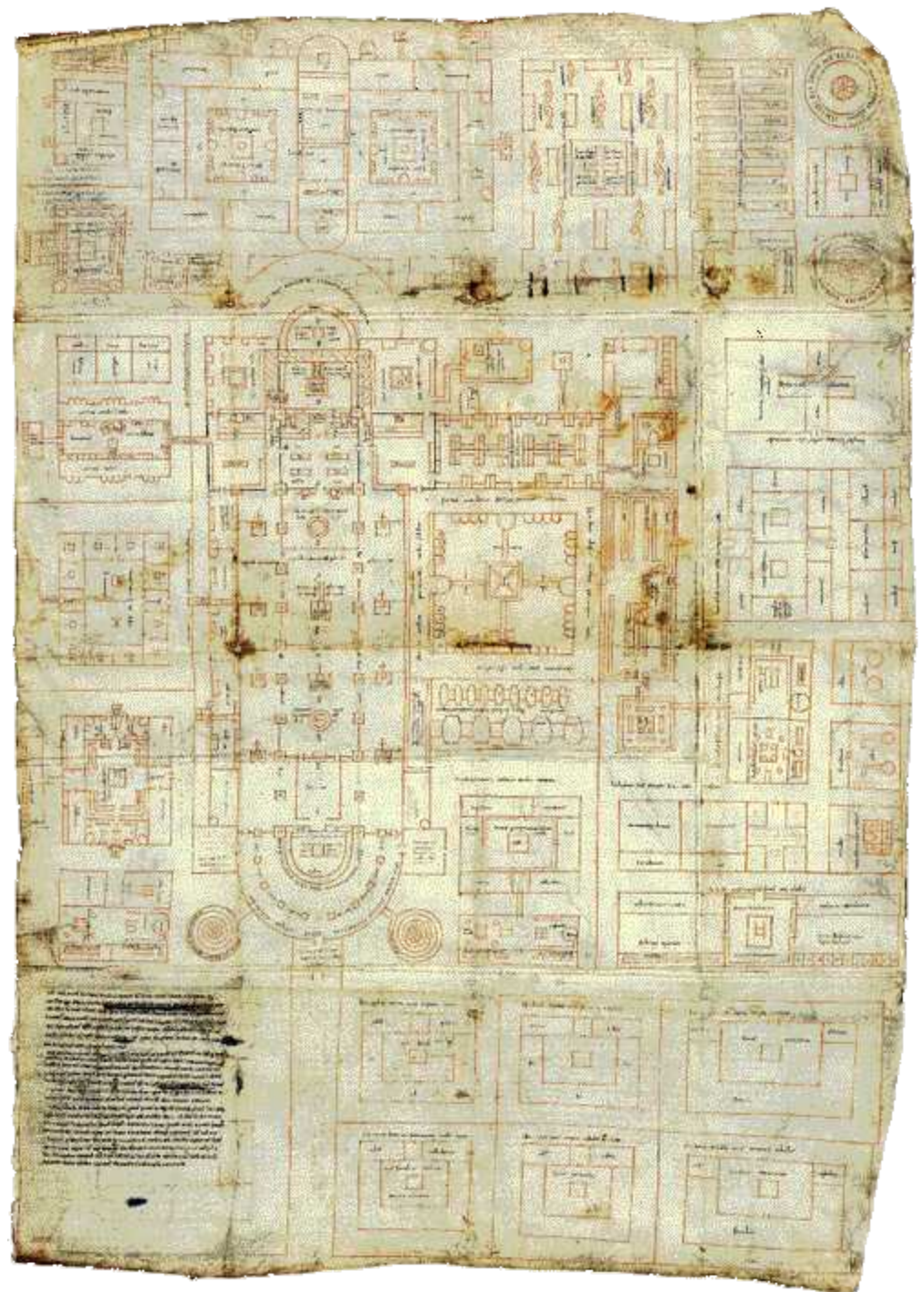

Les vitruviens

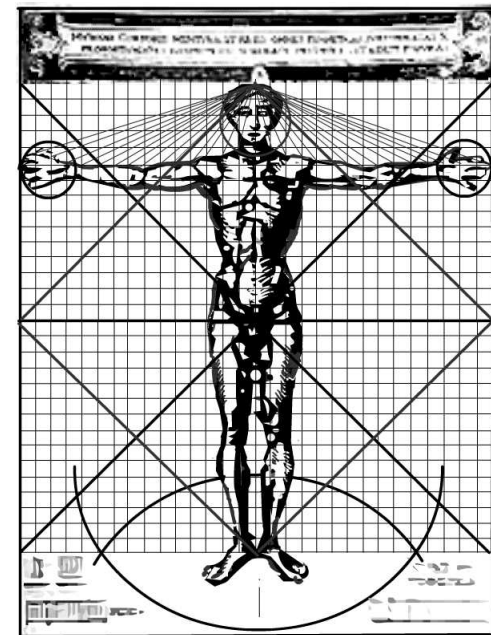
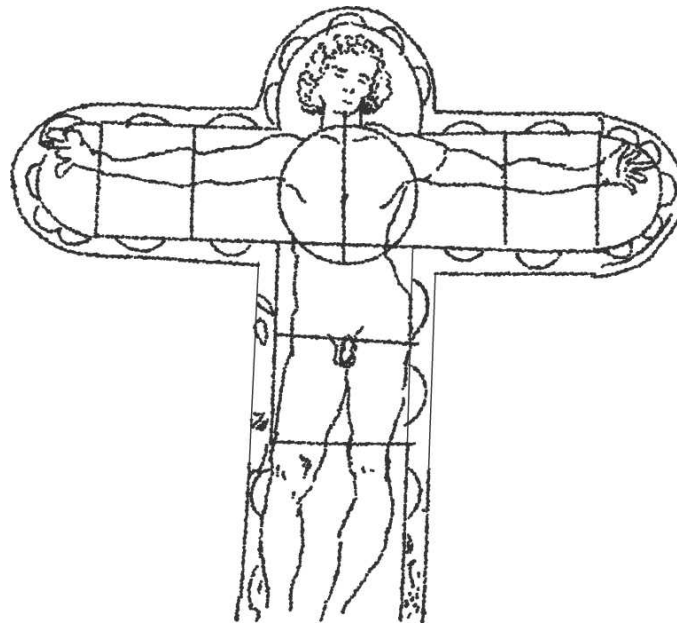
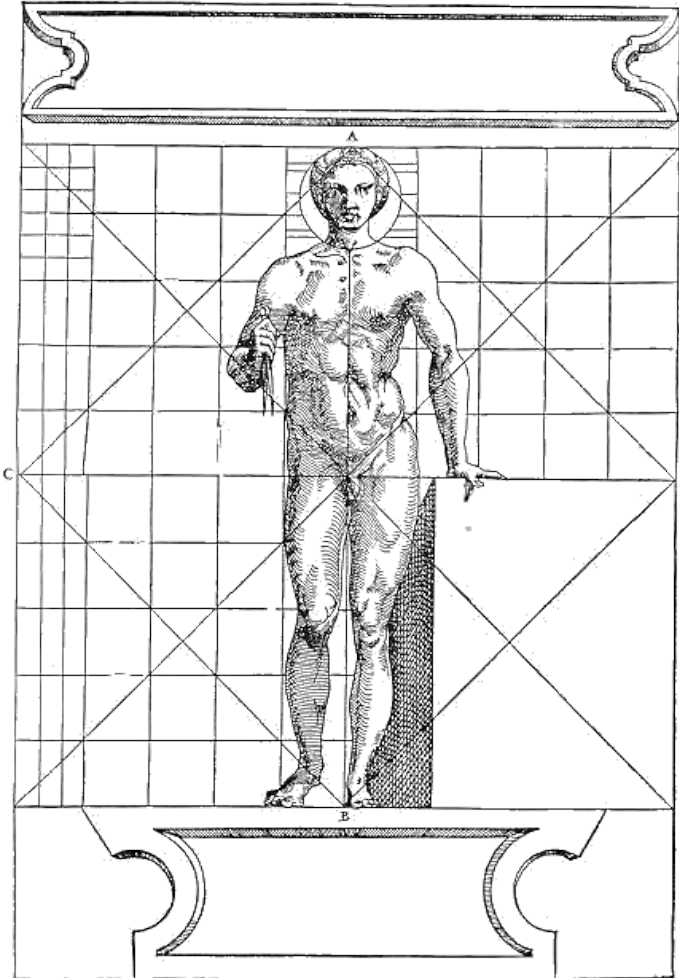
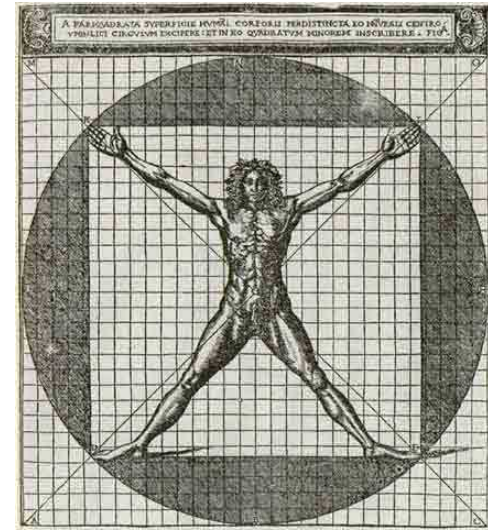
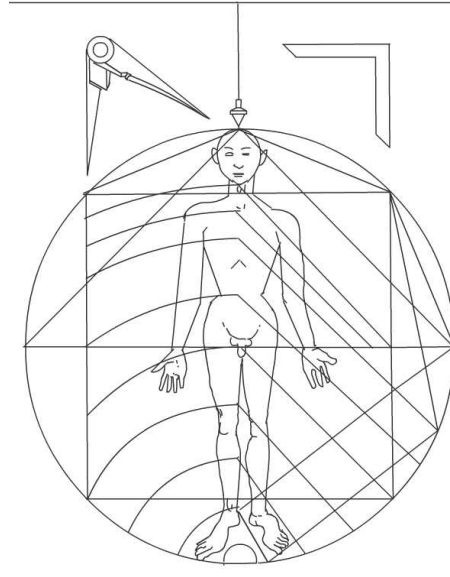
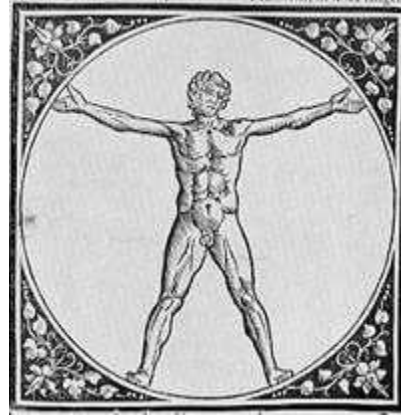



Cornelius Agrippa

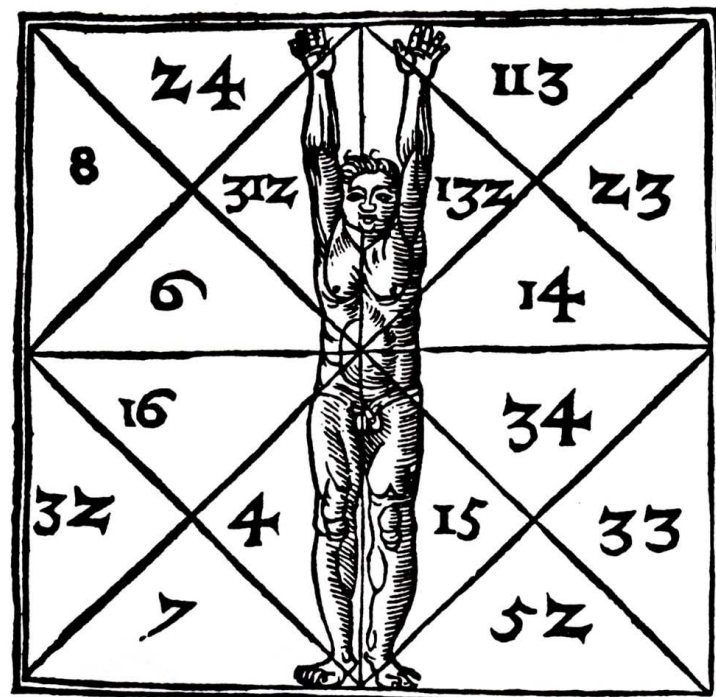

עשראחט עברש ענאדחט
 עחעחחא עחאחנצ פדראזע
 דפידרפיד עחשדזספחא סשר
 עחאאחנצ סשזטשחיד עחסח
 עחפסנזטחנצ סח סשחאדא
 עחפידז סשחסערעכנע
 ספרד פנחא

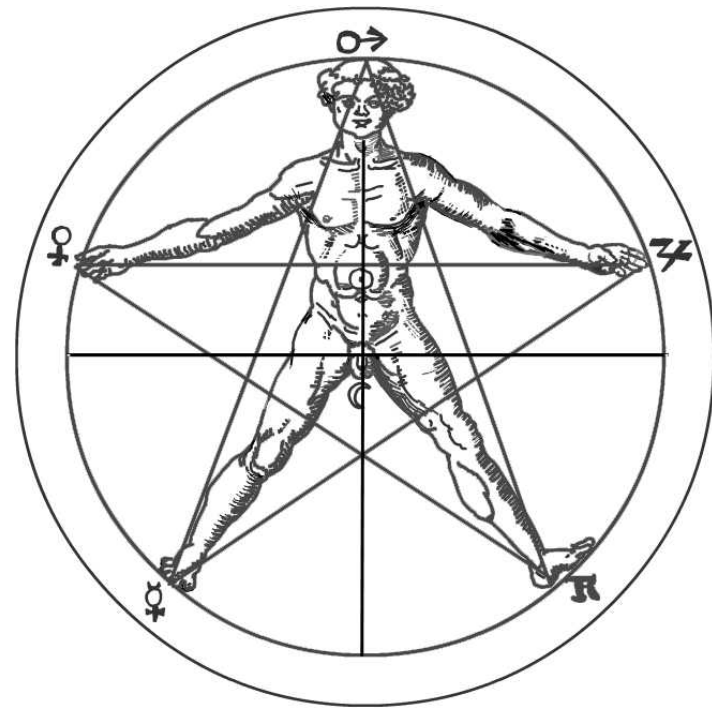

Villard de Honnecourt

XIIIème

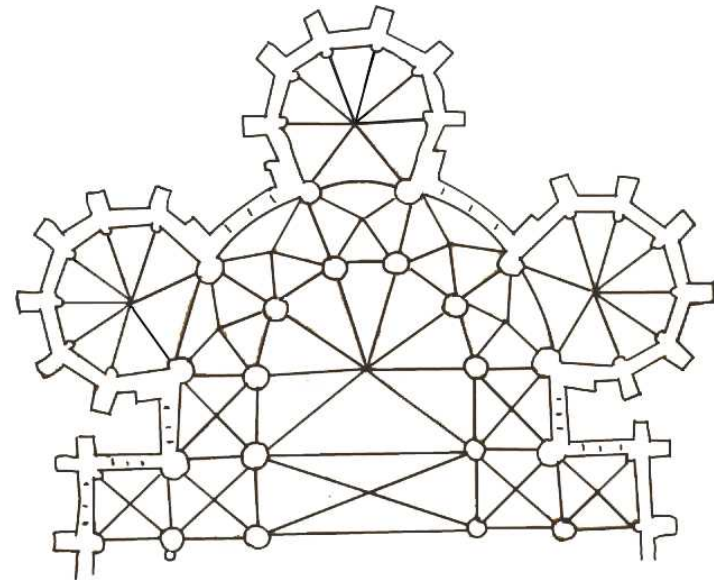
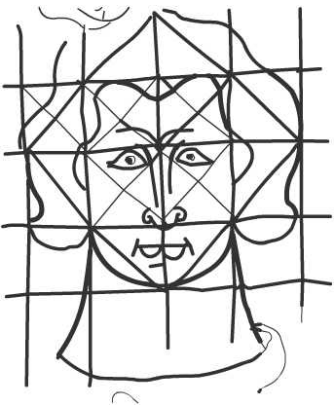
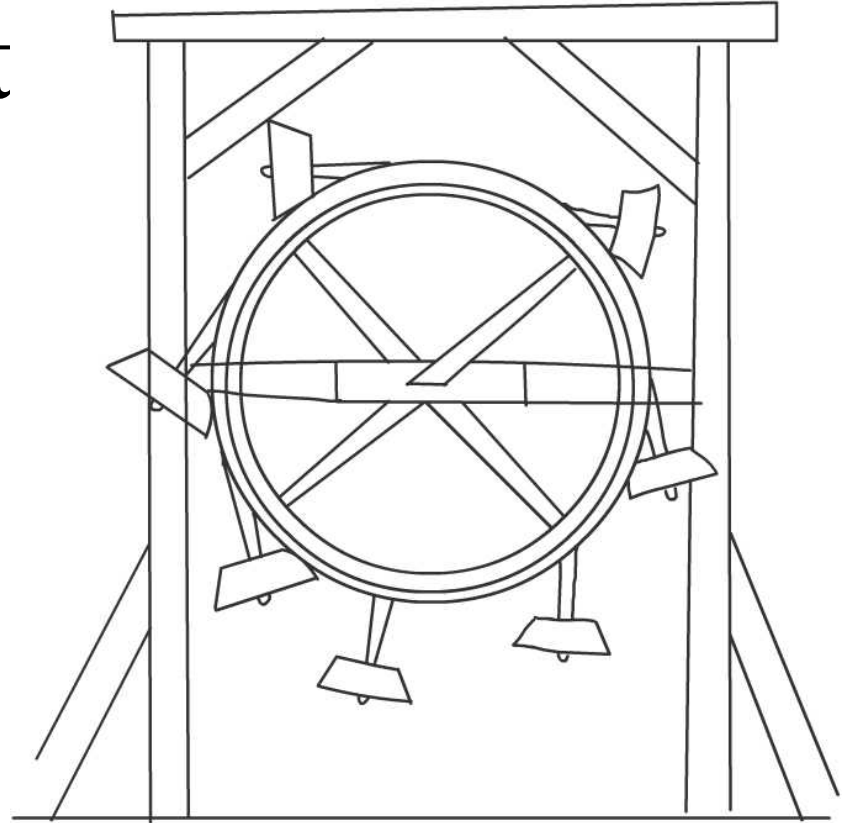
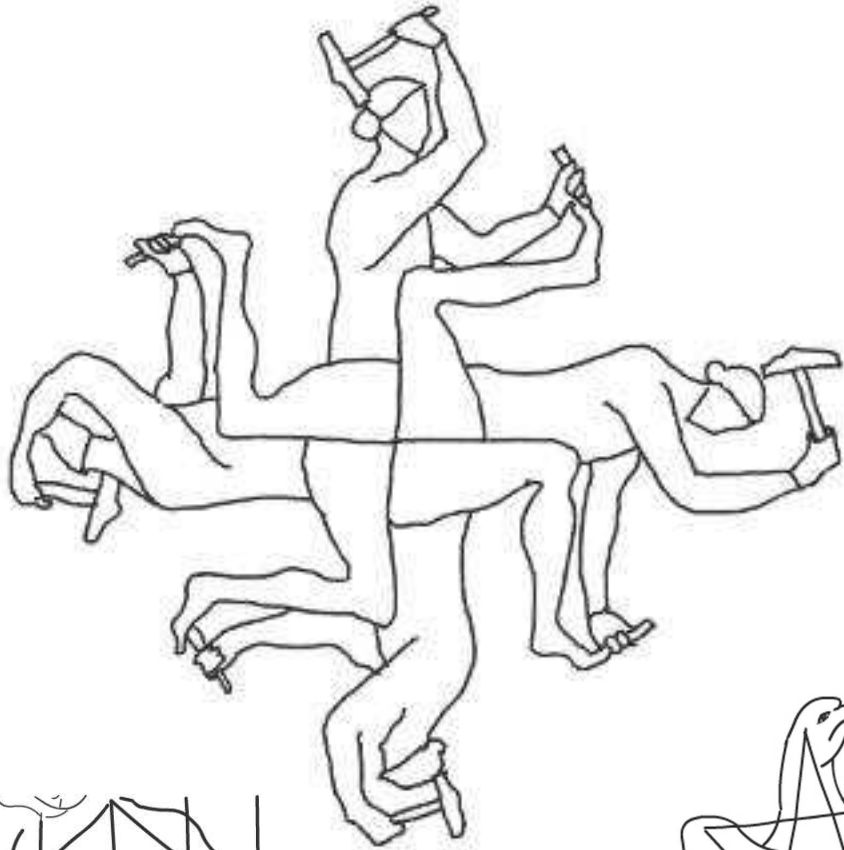

Hildegarde, XIIème



Typographie
Geoffroy Tory
Claude Garamond
Champfleury
Dürer

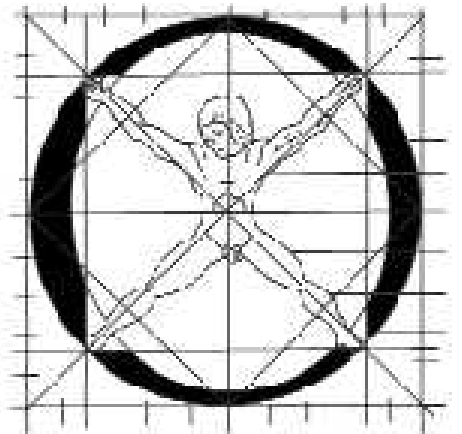
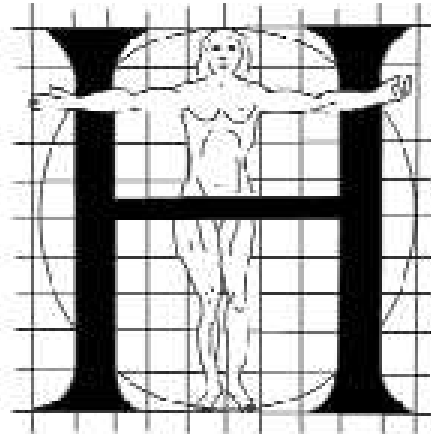
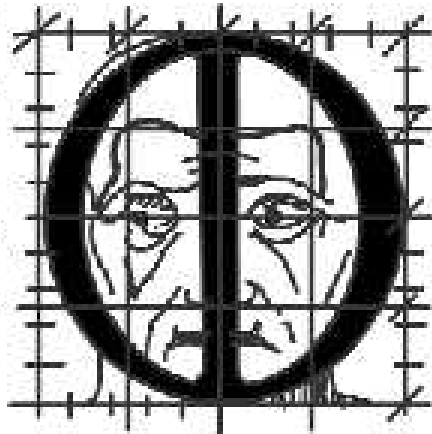
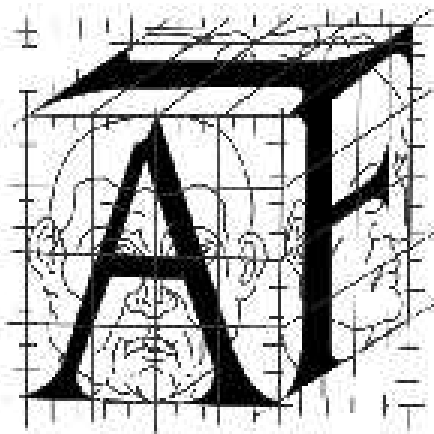

Vinci, animation ?

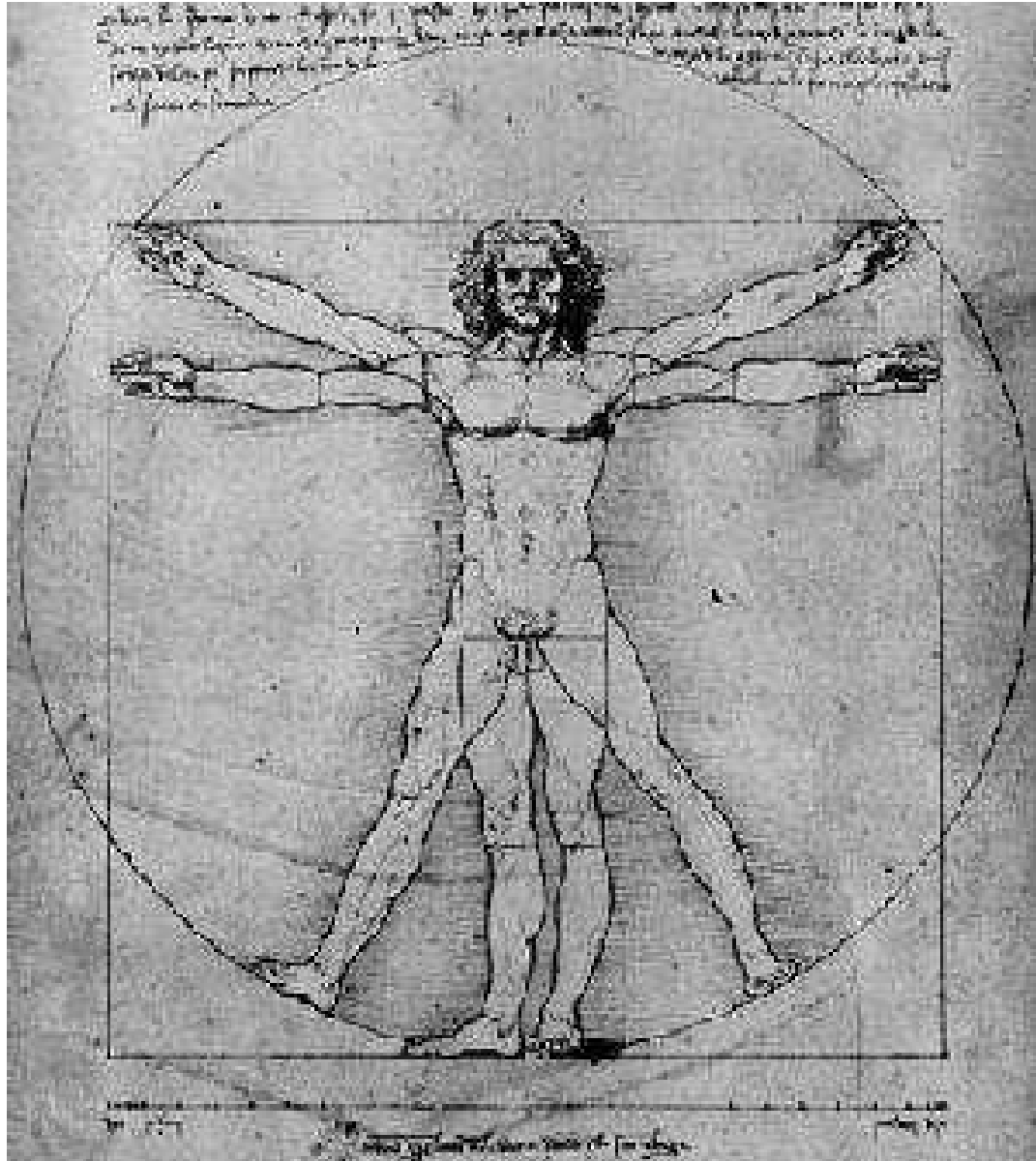

Compagnons, maçons et voyages

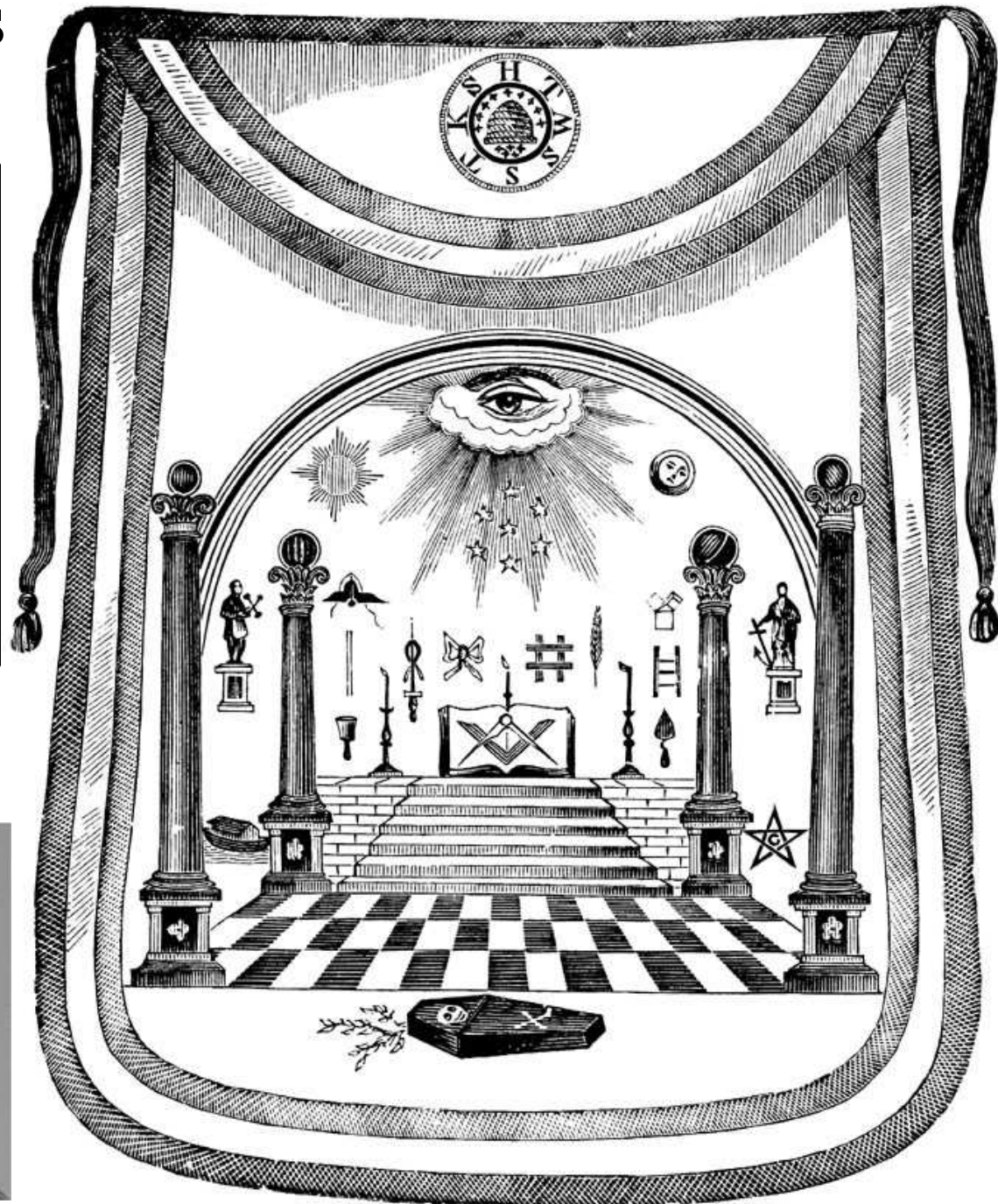
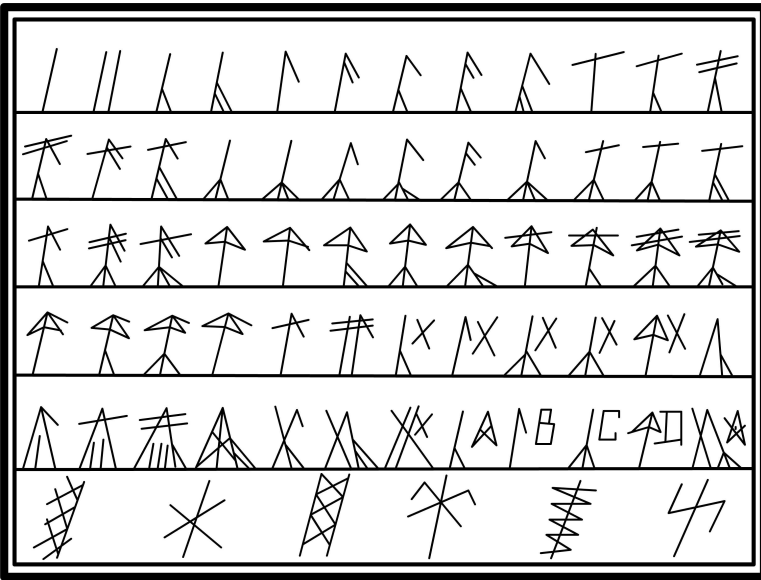

Désert de Retz

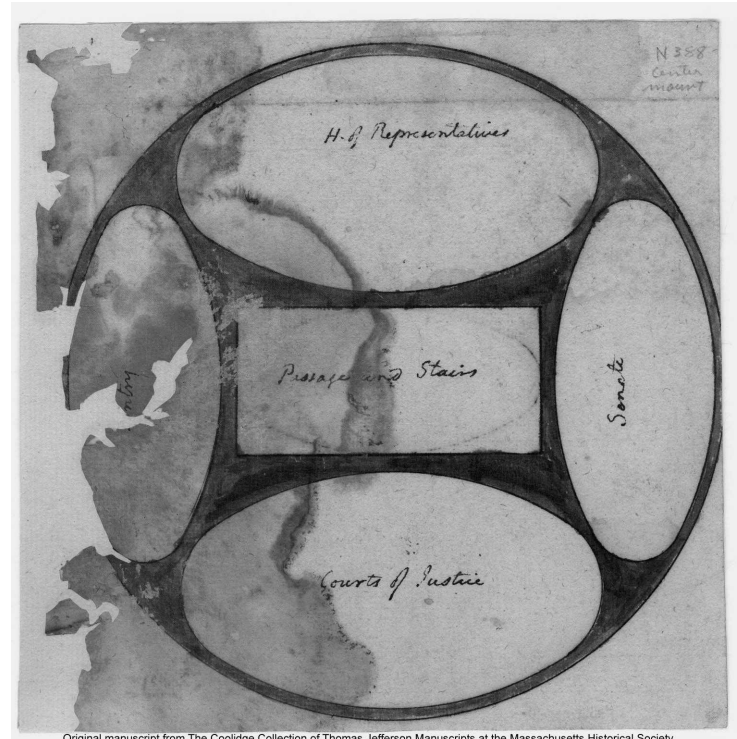
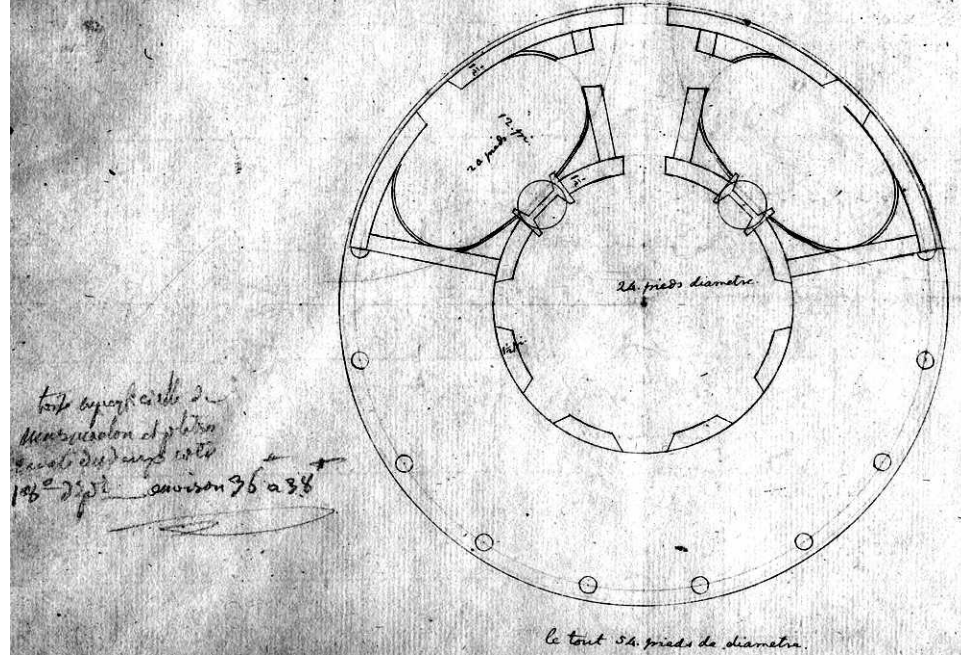
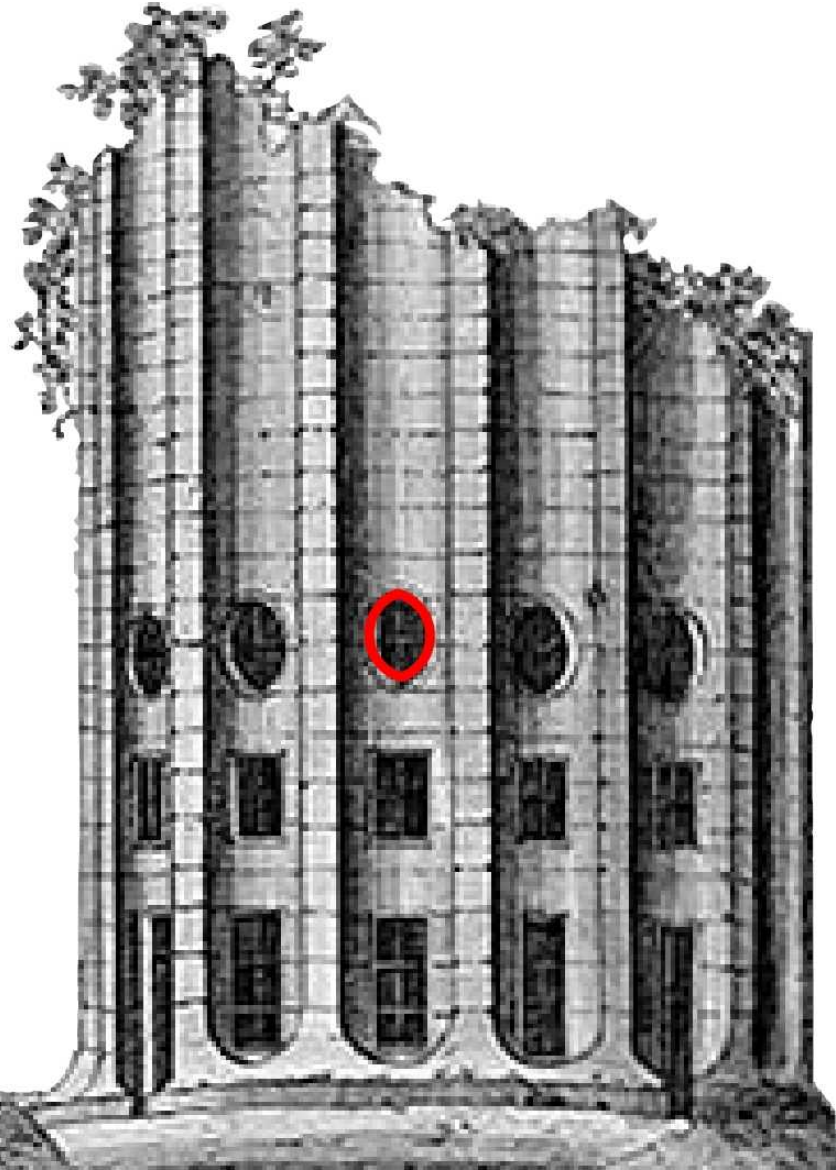

Washington 108°

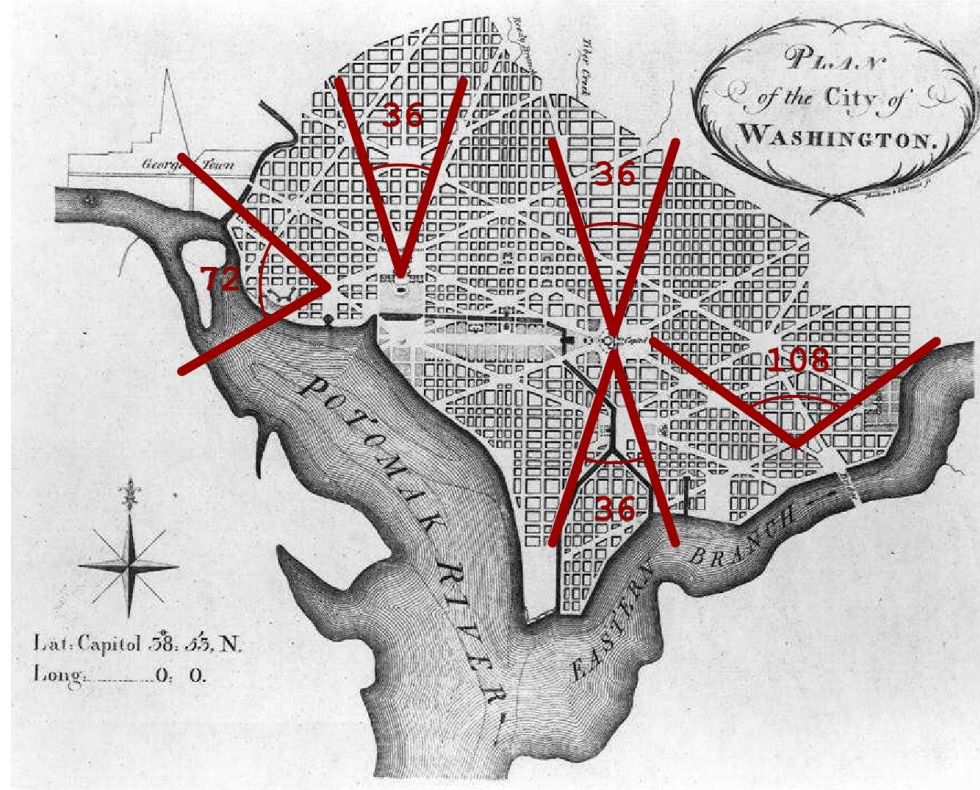

1783

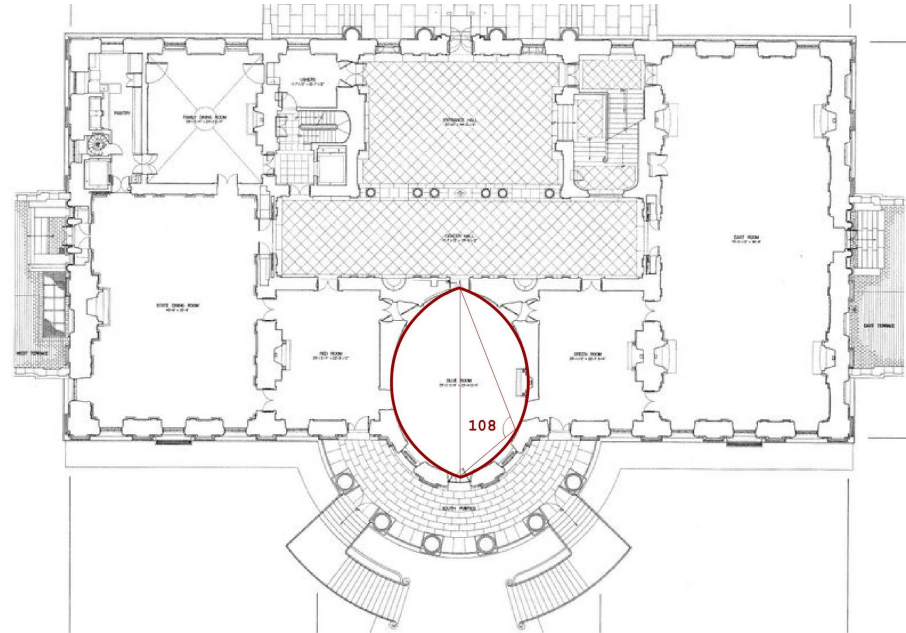
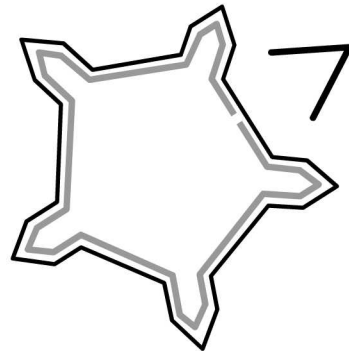

Homophones & Vigenère

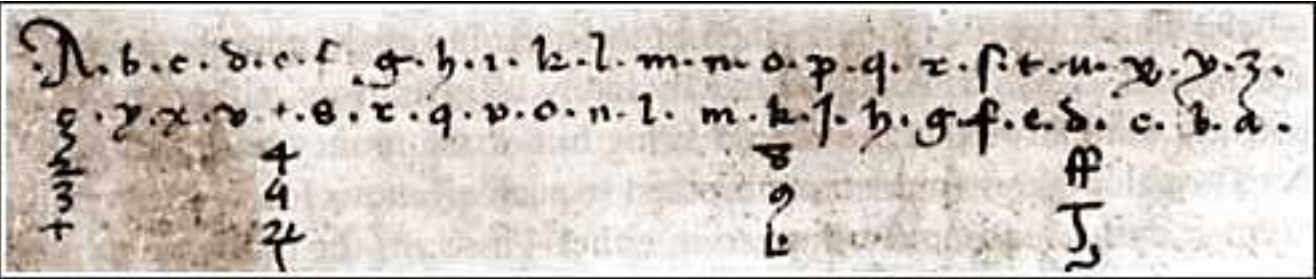

a / 0-1 00dΔ
 a 0Δ a //ff-a
 ya/a/ε 0 c v ε f a c v ff
 caq //v i \a mca a # v i



	A	B	C	D	E	F	G	H	I	J	K	L	M	N	O	P	Q	R	S	T	U	V	W	X	Y	Z
A	A	B	C	D	E	F	G	H	I	J	K	L	M	N	O	P	Q	R	S	T	U	V	W	X	Y	Z
B	B	C	D	E	F	G	H	I	J	K	L	M	N	O	P	Q	R	S	T	U	V	W	X	Y	Z	A
C	C	D	E	F	G	H	I	J	K	L	M	N	O	P	Q	R	S	T	U	V	W	X	Y	Z	A	B
D	D	E	F	G	H	I	J	K	L	M	N	O	P	Q	R	S	T	U	V	W	X	Y	Z	A	B	C
E	E	F	G	H	I	J	K	L	M	N	O	P	Q	R	S	T	U	V	W	X	Y	Z	A	B	C	D
F	F	G	H	I	J	K	L	M	N	O	P	Q	R	S	T	U	V	W	X	Y	Z	A	B	C	D	E
G	G	H	I	J	K	L	M	N	O	P	Q	R	S	T	U	V	W	X	Y	Z	A	B	C	D	E	F
H	H	I	J	K	L	M	N	O	P	Q	R	S	T	U	V	W	X	Y	Z	A	B	C	D	E	F	G
I	I	J	K	L	M	N	O	P	Q	R	S	T	U	V	W	X	Y	Z	A	B	C	D	E	F	G	H
J	J	K	L	M	N	O	P	Q	R	S	T	U	V	W	X	Y	Z	A	B	C	D	E	F	G	H	I
K	K	L	M	N	O	P	Q	R	S	T	U	V	W	X	Y	Z	A	B	C	D	E	F	G	H	I	J
L	L	M	N	O	P	Q	R	S	T	U	V	W	X	Y	Z	A	B	C	D	E	F	G	H	I	J	K
M	M	N	O	P	Q	R	S	T	U	V	W	X	Y	Z	A	B	C	D	E	F	G	H	I	J	K	L
N	N	O	P	Q	R	S	T	U	V	W	X	Y	Z	A	B	C	D	E	F	G	H	I	J	K	L	M
O	O	P	Q	R	S	T	U	V	W	X	Y	Z	A	B	C	D	E	F	G	H	I	J	K	L	M	N
P	P	Q	R	S	T	U	V	W	X	Y	Z	A	B	C	D	E	F	G	H	I	J	K	L	M	N	O
Q	Q	R	S	T	U	V	W	X	Y	Z	A	B	C	D	E	F	G	H	I	J	K	L	M	N	O	P
R	R	S	T	U	V	W	X	Y	Z	A	B	C	D	E	F	G	H	I	J	K	L	M	N	O	P	Q
S	S	T	U	V	W	X	Y	Z	A	B	C	D	E	F	G	H	I	J	K	L	M	N	O	P	Q	R
T	T	U	V	W	X	Y	Z	A	B	C	D	E	F	G	H	I	J	K	L	M	N	O	P	Q	R	S
U	U	V	W	X	Y	Z	A	B	C	D	E	F	G	H	I	J	K	L	M	N	O	P	Q	R	S	T
V	V	W	X	Y	Z	A	B	C	D	E	F	G	H	I	J	K	L	M	N	O	P	Q	R	S	T	U
W	W	X	Y	Z	A	B	C	D	E	F	G	H	I	J	K	L	M	N	O	P	Q	R	S	T	U	V
X	X	Y	Z	A	B	C	D	E	F	G	H	I	J	K	L	M	N	O	P	Q	R	S	T	U	V	W
Y	Y	Z	A	B	C	D	E	F	G	H	I	J	K	L	M	N	O	P	Q	R	S	T	U	V	W	X
Z	Z	A	B	C	D	E	F	G	H	I	J	K	L	M	N	O	P	Q	R	S	T	U	V	W	X	Y

Le télégraphe Chappe

1792 - 1854 ... et portable

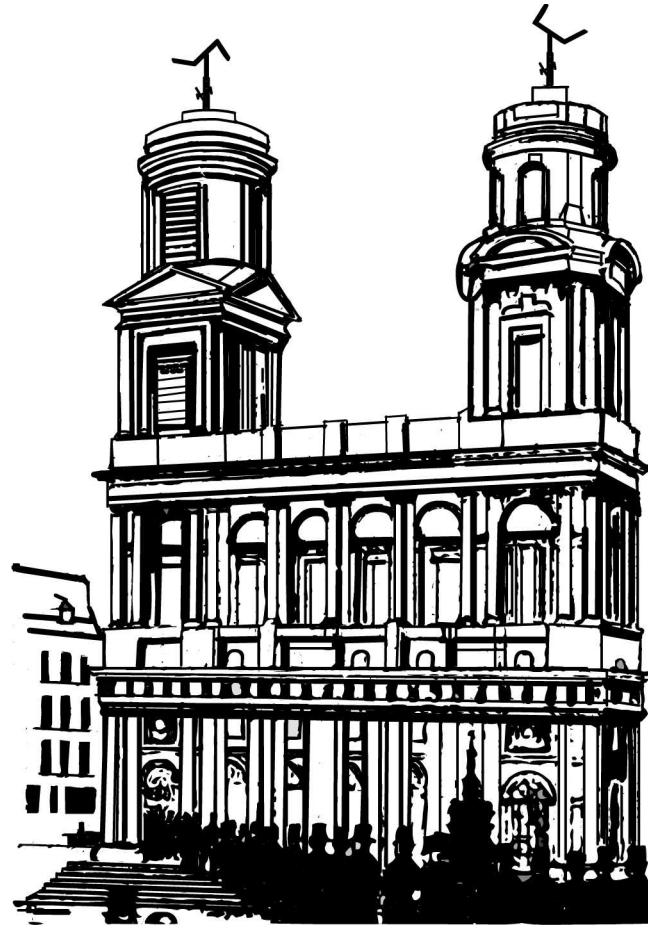
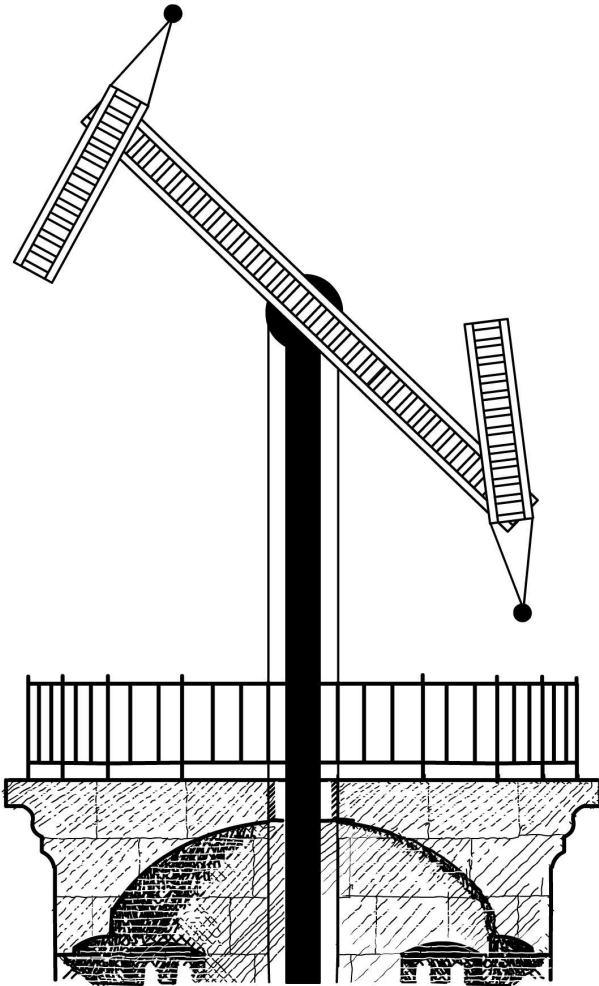
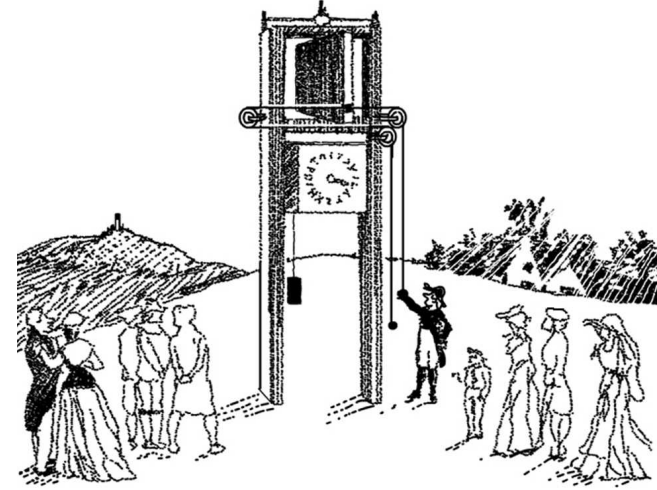

Marcel Duchamp

1915-1923

1912



Enigma de Arthur Scherbius

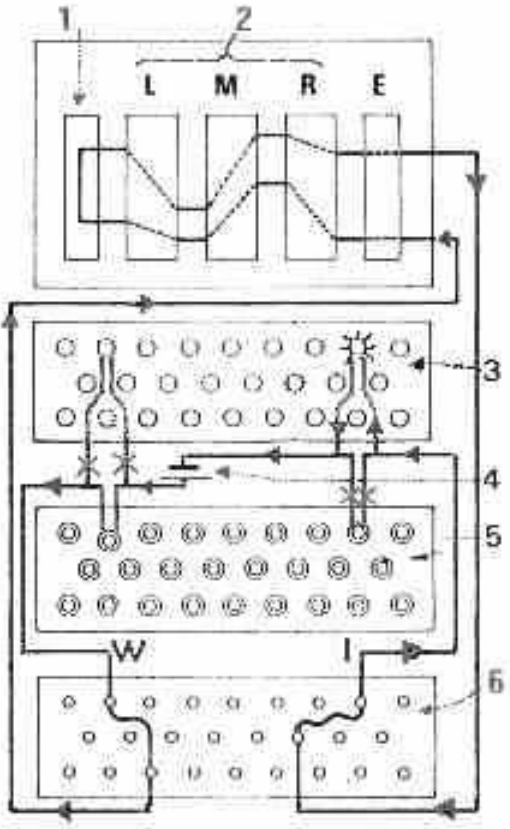
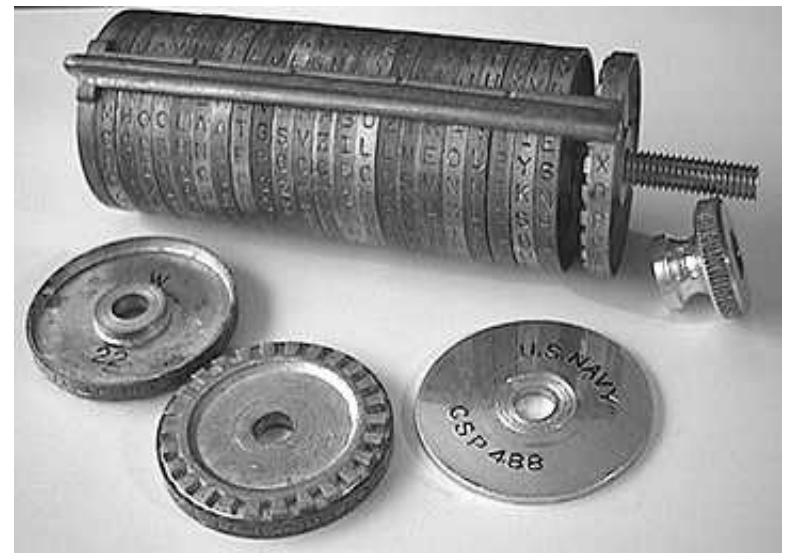

1918



Turing, même

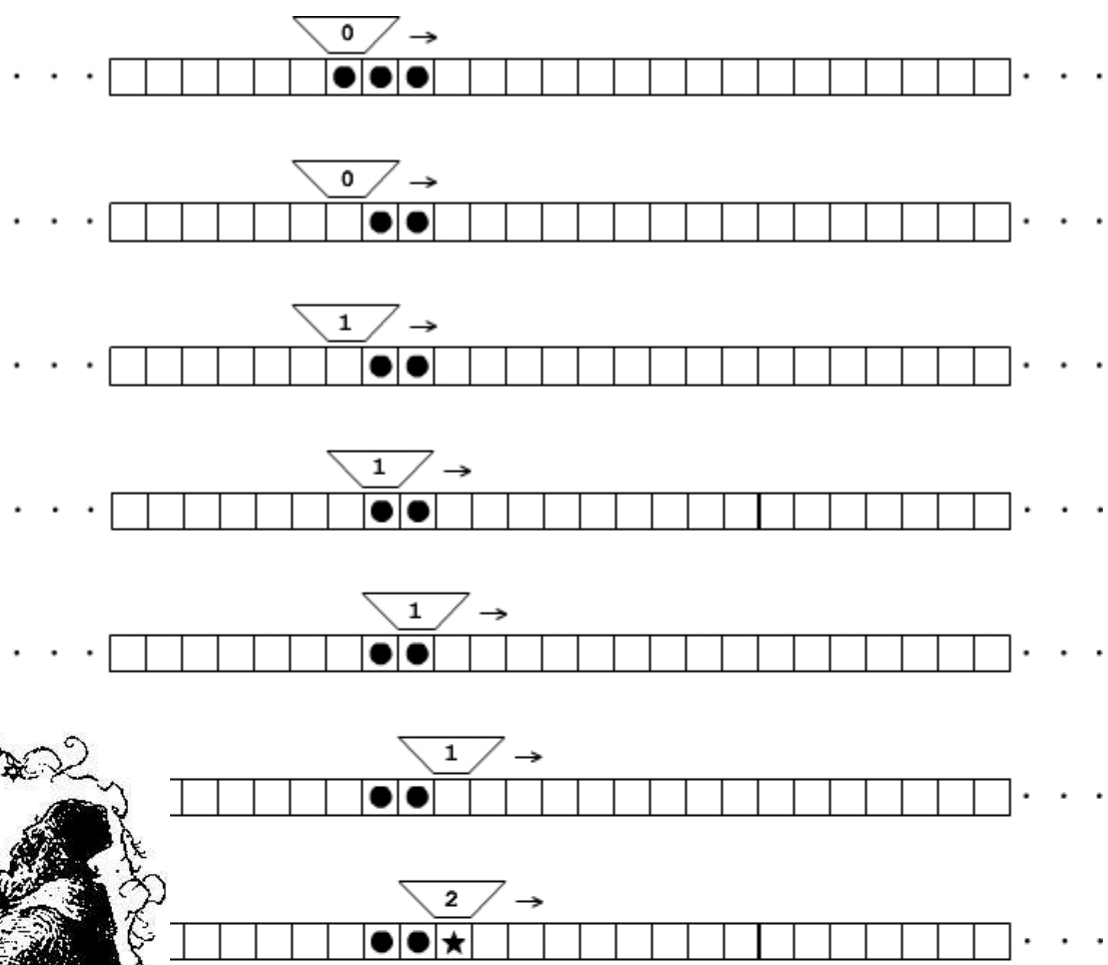
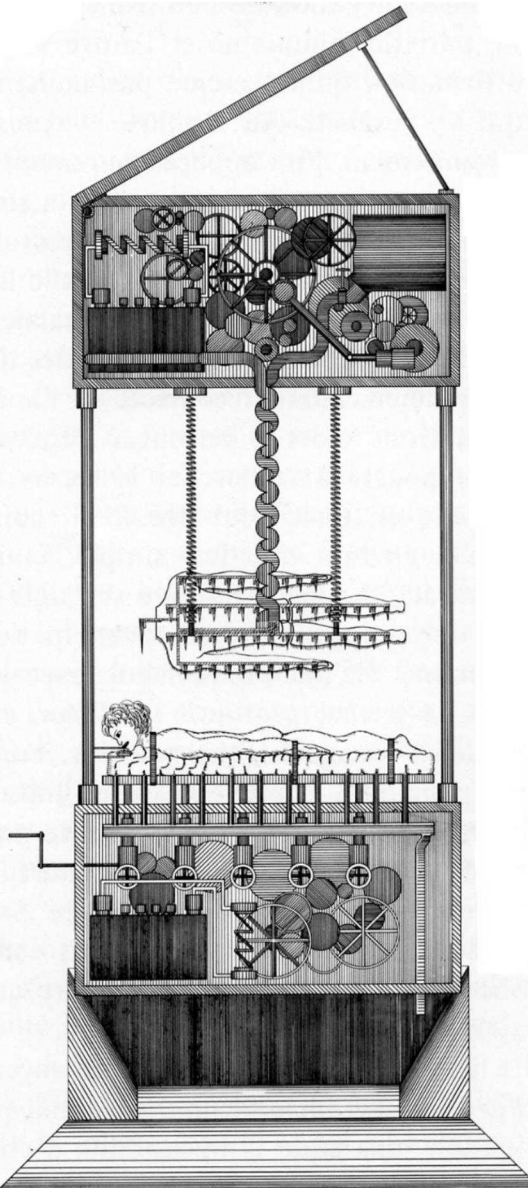

1912-1954



Emigration en Codeland



Total Residents:	1,585,706
Logged In Last 60 Days:	644,826
Online Now:	13,492
US\$ Spent Last 24h:	<u>\$653,241</u>
Lindex Activity Last 24h:	<u>\$79,293</u>



Salon du code



Codex Vindobonensis.

Handwritten text in a cursive script from the Codex Vindobonensis, featuring various ligatures and decorative flourishes.

Handwritten text in a cursive script, likely a continuation of the Codex Vindobonensis, showing dense, flowing characters.



Pa	Veh	Ged	Gal	Or	Un	Graph	Tal	Gon
b	c, k	g, j	d	f	a	e	m	i
Ur	Mals	Ger	Drux	Pal	Med	Don	Ceph	Van
l	p	q	n	x	o	r	z	u/v

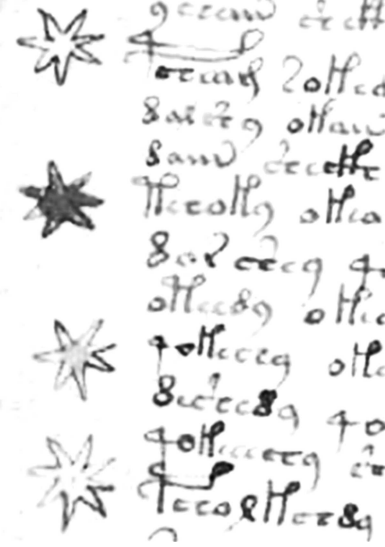

A	B	C	D	E	F	G
N	O	P	Q	R	S	T

Handwritten text in a stylized, blocky script, possibly representing a specific code or cipher.

Handwritten text in a stylized, blocky script, possibly representing a specific code or cipher.

A	B	C	D	A	B	C	D	E
N	O	P	Q	R				

Handwritten text, possibly a signature or a specific code label.

pioneer
1972

